



TA Series Analog VoIP Gateway Installation Guide

Version 1.3

Date: July 10, 2015

Yeastar Information Technology Co. Ltd.

Contents

About TA Series Analog VoIP Gateway	3
1. Preparation before Installation	4
2. Hardware Specifications	5
2.1 Overview.....	5
2.2 LED Indicators and Ports	6
2.3 Specifications and Operating Environment.....	8
3. Yeastar TA Series Installation.....	10
3.1 Placement Instructions.....	10
3.2 Installation Instructions.....	10
3.2.1 Wall-mount Instruction	10
3.2.2 Connection of Ethernet Ports	11
3.2.3 Connection of FXS Ports	11
3.2.4 Connection of FXO Ports.....	12
3.2.5 Power Connection	12
3.2.6 Connection Diagram	12
4. TA Series Basic Configurations	14
4.1 Getting an IP Address	14
4.2 Logging in the Web Configuration Panel	15
4.3 Network Settings.....	15
4.4 Make and Receive Calls	16
4.5 Reset to Factory Defaults.....	16
5. Conclusion.....	17

About TA Series Analog VoIP Gateway

Yeastar TA Analog VoIP Gateways are cutting-edge products that connect legacy telephones, fax machines and PBX systems with IP telephony networks and IP-based PBX systems. Featuring rich functionalities and easy configuration, Yeastar TA is ideal for small and medium enterprises that wish to integrate a traditional phone system into IP-based system. Yeastar TA helps them to preserve previous investment on legacy telephone system and reduce communication costs significantly with the true benefits of VoIP.

This Guide explains how to install Yeastar TA Analog VoIP Gateway, how to log in web interface, etc.

1. Preparation before Installation

Please make sure the following devices are available before installation

➤ Contents of the box

Upon receiving Yeastar TA gift box, please open the package and check if all the items are supplied as TA400/410/800/810 Packing List (See Sheet 1) and TA1600/1610/2400/3200 Packing List (See Sheet 2). If there is any problem, please contact your provider.

Sheet 1 TA400/410/800/810 Packing List

Item	Unit	QTY	Description
TA400/410/800/810	PC	1	device unit
Power adaptor	PC	1	Power Supply
Network cable	PC	1	
Stand	PC	1	
Warranty card	PC	1	With Serial Number printed for Repair & Return
Quick installation guide	PC	1	

Sheet 2 TA1600/1610/2400/3200 Packing List

Item	Unit	QTY	Description
TA1600/2400/3200	PC	1	device unit
Power cord	PC	1	For the input of power
Network cable	PC	1	
Warranty card	PC	1	With Serial Number printed for Repair & Return
Quick installation guide	PC	1	
Mounting ears	PC	2	
Screws	PC	8	8 screws (φ3.0*6 mm) for mounting ears
Grounding stud and nut	Pair	1	
Rubber feet	PC	4	

2. Hardware Specifications

2.1 Overview



Figure 2-1 TA Series Analog VoIP Gateways

Table 2-1 Yeastar TA Telephony Interfaces

Models	Telephony Interfaces		
	RJ11 FXS Ports	RJ11 FXO Ports	RJ21 FXS Ports
TA400	4	–	–
TA410	–	4	–
TA800	8	–	–
TA810	–	8	–
TA1600	16	–	1
TA1610	–	16	1
TA2400	24	–	1
TA3200	32	–	2

2.2 LED Indicators and Ports

The LED indicators and ports of TA400, TA410, TA800, and TA810 are similar; the difference is the number for ports and the type of ports. Take the front panel and rear panel of TA800 and TA3200 as examples.

➤ Front Panels

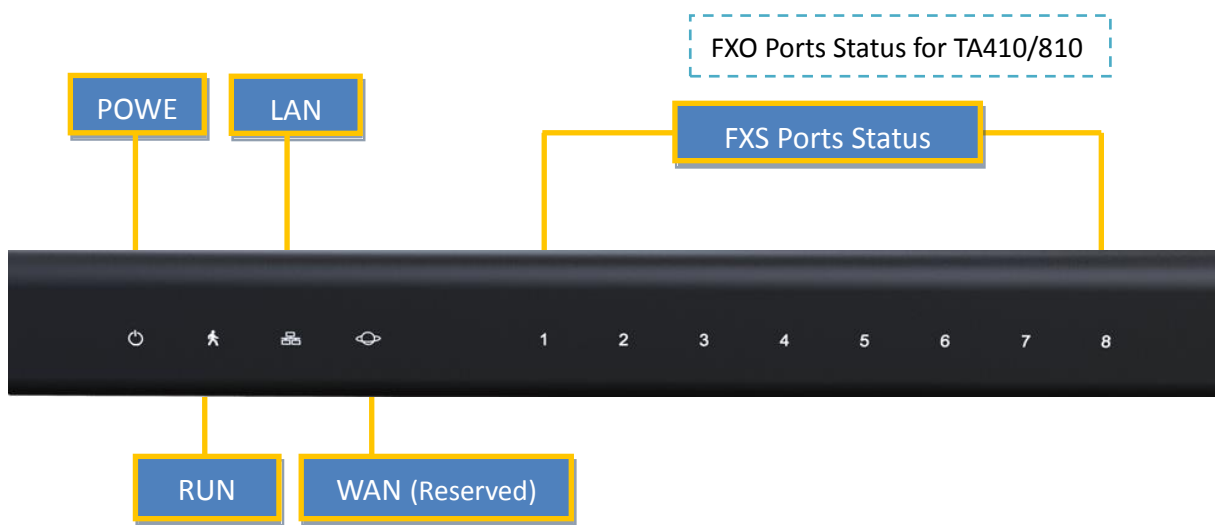

Figure 2-2 TA800 Front Panel

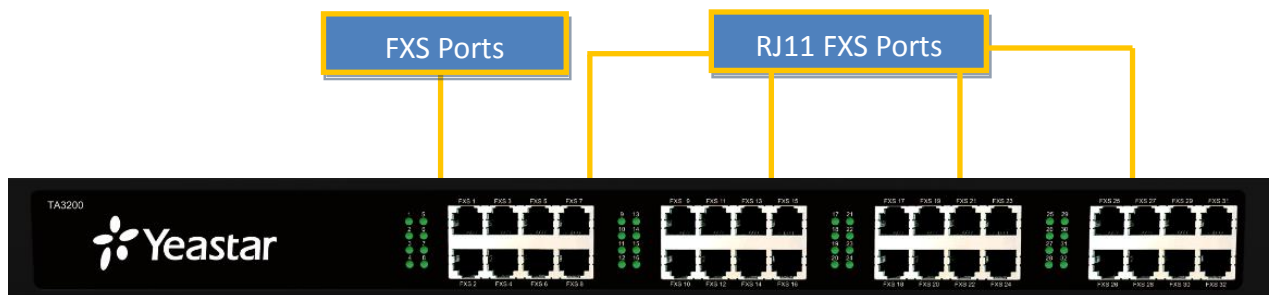

Figure 2-3 TA3200 Front Panel

➤ Rear Panels

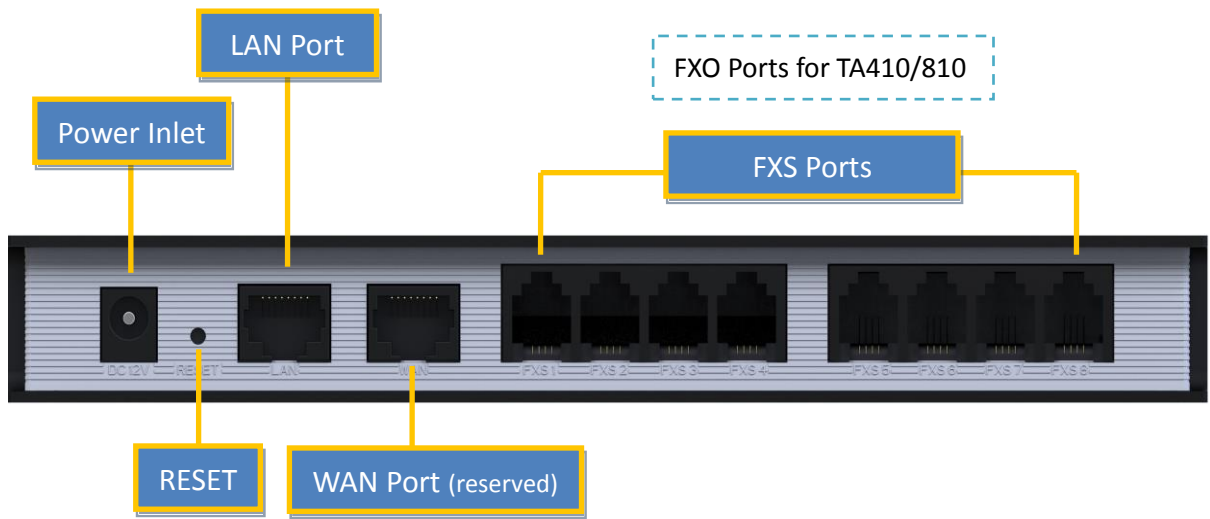

Figure 2-4 TA800 Rear Panel

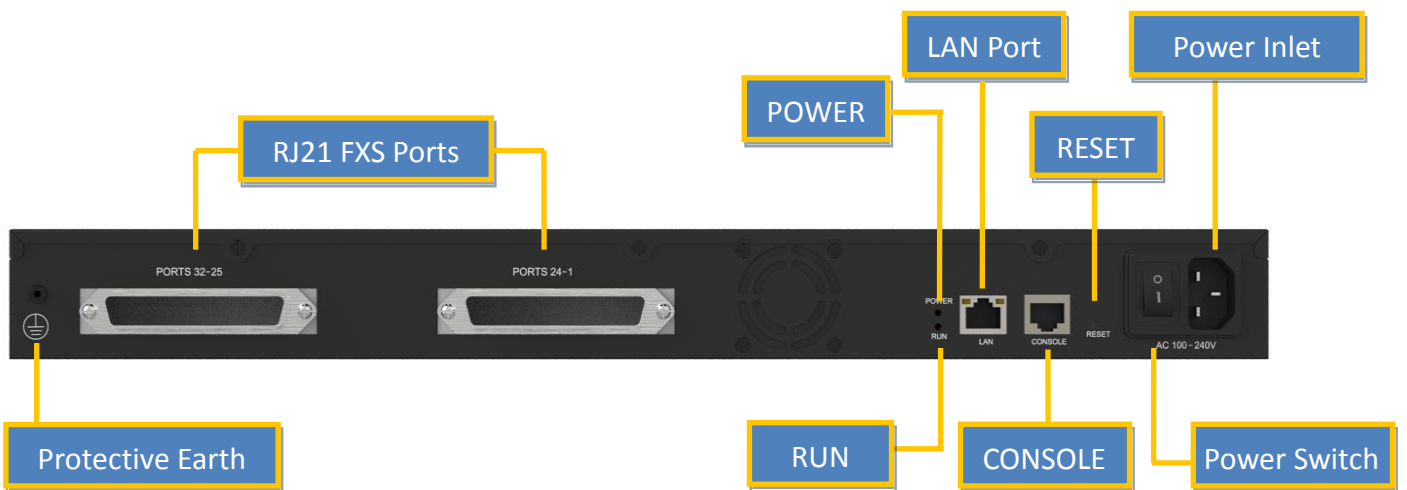



Figure 2-5 TA3200 Rear Panel

Table 2-2 LED Indications

LED	Indication	Status	Description
POWER	Power status	On	The power is switched on.
		Off	The power is switched off.
RUN	status	Blinking	is running properly.
		Not Blinking/Off	goes wrong.
1-32	FXS Ports Status	Green light	Solid green: the port is idle.
1-8	FXO Ports Status		Green light blinking: there is an ongoing call on the port.

Table 2-3 Ports Descriptions

Ports	Description
Ethernet Port	provides 1 10/100 adaptive RJ45 Ethernet ports, marked as LAN. - LAN port : LAN port is for the connection to Local Area Network (LAN).
Reset Button	Press the reset button to restore the factory defaults.  Please make sure that you want to reset, because once reset the previous configurations would be erased automatically.
Power Inlet	For connection of power supply.
RJ11 FXS Ports	For connection of analog phones/fax machines.
RJ11 FXO Ports	For connection of PSTN interfaces or PBX extension interfaces.
RJ21 FXS Ports	For connection of analog phones/fax machines with an RJ21 to RJ11 cable.
RS232 Console Port (TA1600/1610/2400/3200)	For debugging.

2.3 Specifications and Operating Environment

Table 2-4 TA400/410/800/810 Specifications and Operating Environment

TA400/410/800/810	Description
Size (LxWxH)	200 mm x 137 mm x 25 mm
Power Supply	12V 1A
Operating Temperature	0 to 40°C, 32 to 104°F
Storage Temperature	-20 to 65°C, 4 to 149°F
Humidity	10%~90% (Non-condensing)

Table 2-5 TA1600/1610/2400/3200 Specifications and Operating Environment

TA1600/1610/2400/3200	Description
Size (LxWxH)	440 mm x 250 mm x 44 mm
Power Supply	AC 100-240V 50/60Hz
Operating Temperature	0 to 40°C, 32 to 104°F
Storage Temperature	-20 to 65°C, 4 to 149°F
Humidity	10% to 90% (non-condensing)

3. Yeastar TA Series Installation

To avoid unexpected accident, personal injury or device damage, please read the following instructions before installing the Gateway.

3.1 Placement Instructions

- ◆ Ambient Temperature: to avoid overheating, please do not run Yeastar TA in the place where the ambient temperature is above 104°F (40°C).
- ◆ Ventilation: please make sure that the device has good ventilation around.
- ◆ Anti-jamming: there may be some sources of interference that might affect the normal running of the Gateway. It's highly recommended that the device
 - Should be placed away from high-power radio, radar transmitters and high frequency, and high-current devices.
 - Is using independent power junction box and effective anti-grid interference measures have been taken.
- ◆ Mechanical load: Please make sure that the device is placed steadily to avoid any accident that might cause damage. If placed on the desktop, please ensure it is horizontally placed.

3.2 Installation Instructions

Place the Gateway in a suitable place, and then connect the power adapter and all other cables to complete the installation.

3.2.1 Wall-mount Instruction

Yeastar TA400/410/800/810, besides being a desktop device, is also wall-mountable. Mounting the device on the wall could save some space if space is limited.

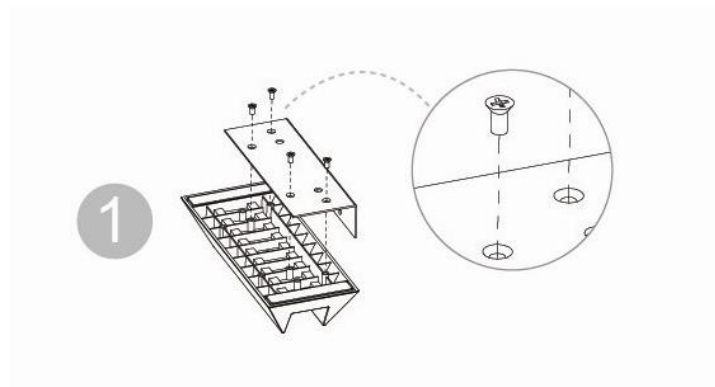

Remove the screws on the stand. The screw the clump weight to the stand again to the stand as the picture shows.

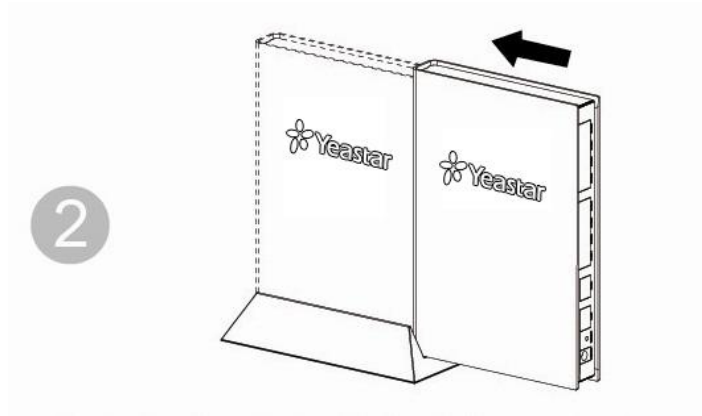

Push the TA device into the stand.

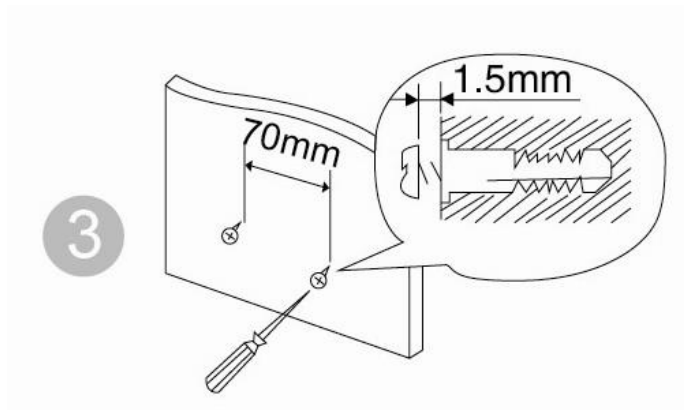

Fix two screws on the wall and then you could mount the stand to the wall.

3.2.2 Connection of Ethernet Ports

Yeastar TA provides one 10/100M adaptive RJ45 Ethernet LAN port.

◆ LAN Port Connection

Connect one end of a network cable to the LAN port of the Gateway, and the other end to any port of company's LAN switch/router.

3.2.3 Connection of FXS Ports

TA FXS Gateways are available with 5 models, supporting up to 32 FXS ports.

◆ RJ11 Phone Port

Connect one end of a RJ11 phone cable to the port. Connect the other end to your analog telephone.

◆ RJ21 Connection

Applicable to TA1600/2400/3200.

Connect one end of a RJ21 cable to the connector. Connect the other ends to your analog telephones.

3.2.4 Connection of FXO Ports

TA FXO Gateways include TA410, TA810, and TA1610, supporting 4, 8, and 16 FXO ports respectively.

Connect the FXO interfaces to the Public Telephone Network (PSTN) or a PBX extension interface.

3.2.5 Power Connection

Connect the power adapter to the Gateway's power port, and then plug the power adapter into an electrical outlet. Press the On switch to power on the Gateway. The gateway will start booting. In the meantime, users would see that the "POWER" and "RUN" indicator lights turn on.

Note: Please switch off the power before plugging or unplugging the cables.

3.2.6 Connection Diagram

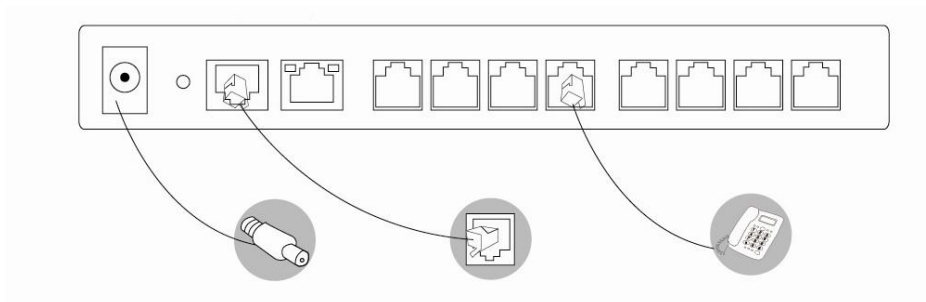

Figure 3-1 TA800 Connection Diagram

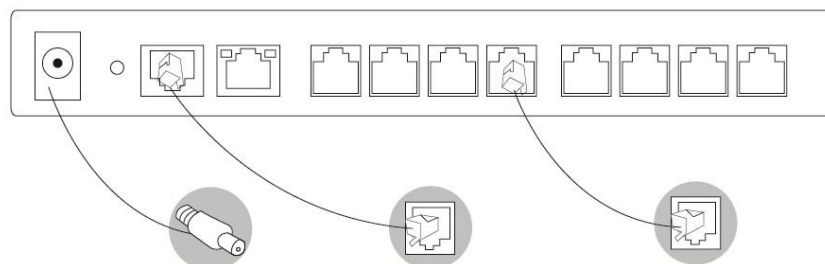

Figure 3-2 TA810 Connection Diagram

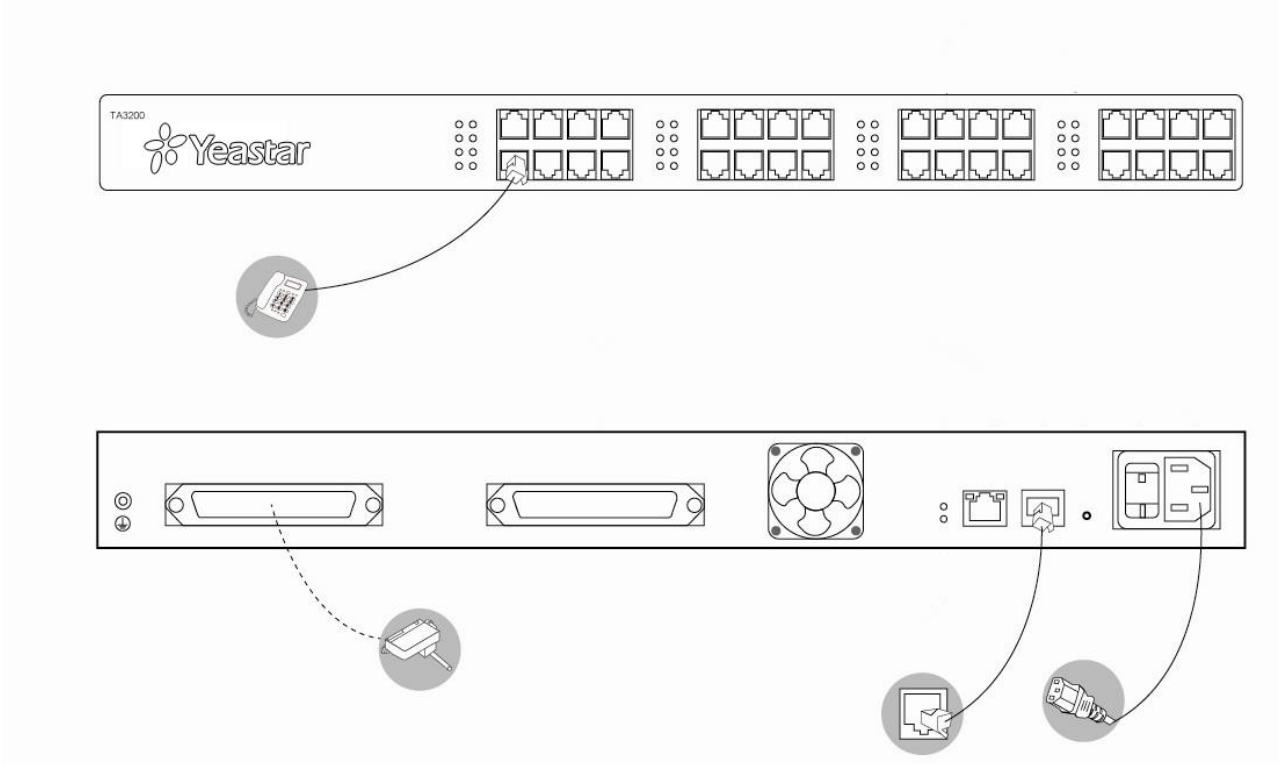

Figure 3-3 TA3200 Connection Diagram

4. TA Series Basic Configurations

4.1 Getting an IP Address

Yeastar TA provides web-based configuration interface for administrator and account user. The user can manage the device by logging in the Web interface.

- **Access path:** http://[IP address]
- **User Name:** admin
- **Password:** password
- **Default SIP UDP port:** 5060

The TA attempts to contact a DHCP server in your network to obtain valid network settings (e.g., the IP address, subnet mask, default gateway address and DNS address) by default.

Please enable DHCP Server in your network to obtain the IP address.

Due to the difference of telephony interface, TA FXS Gateway and FXO Gateway will use different methods to check the IP address.

TA FXS Gateway

1. Use an analog phone connected to the FXS port of the Gateway, press *** to get into the IVR menu. Enter 1 to obtain the Gateway's IP address.
2. If there is no DHCP server in the network, press 3 for advanced setting, and press 2 to assign a static IP address to the device.

TA FXO/FXS Gateway

1. Download a DeviceFound tool from Yeastar website: [FindTA.rar](#)
2. Run the DeviceFound.exe software.
3. Find the IP address by the device's MAC address or the SN.

4.2 Logging in the Web Configuration Panel

Start the browser on PC. In the address bar, enter the IP address, click “Enter” button and then you can see Web Configuration Panel login page. Enter the Admin User Name and Password to log in.

VoIP Analog Gateway for Cost Reduction

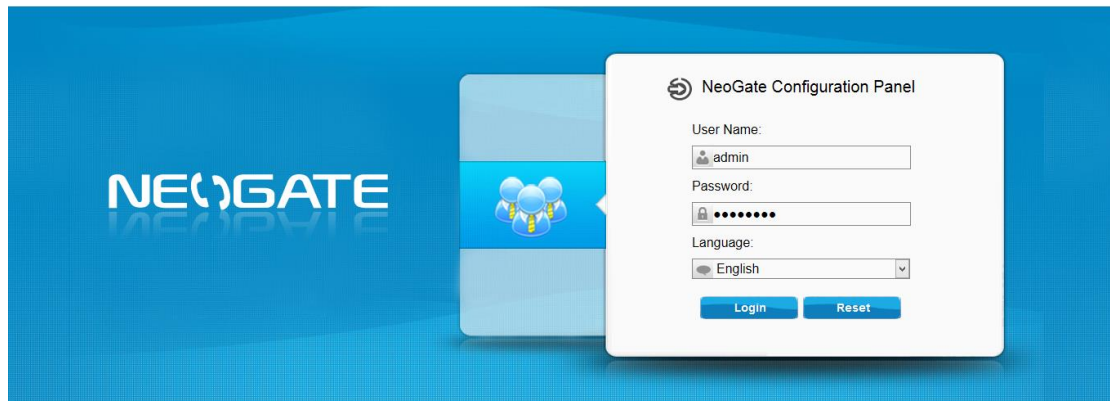

Copyright © 2006-2015 Yeastar Information Technology Co., Ltd. All Rights Reserved.

Figure 4-2 TA Web Configuration Panel Login Page

Via the configuration interface, the admin can make all the system configurations, including network settings (LAN, WAN, Firewall, VPN, DDNS, VLAN, etc.); system parameters configuration (time zone, password, etc.); internal settings (Web access port, etc.); FXS ports list; FXO ports list; Hunting Groups; Hotline; call logs (search, download); firmware update and reset, etc.

Note: after saving the changes, remember to click the “Apply changes” button to make the changes take effect.

4.3 Network Settings

After logging in the admin configuration interface, generally the first step is to configure the IP address. If the LAN ports are connected to the network, their IP addresses need to be configured. If not, just configuring the IP address of the LAN port which is connected to the local area network of the company is OK.

◆ LAN Settings

Click “Network Preferences”→ “LAN Settings” on the left menu bar of the web configuration interface. LAN port is used for the interoperability of IP terminals and . If the LAN port is connected to the company’s LAN, please configure the correct IP address and corresponding subnet mask.

Note: please note that after changing the IP address of LAN port, TA device should be rebooted to make the new changes to take effect.

4.4 Make and Receive Calls

- **TA FXS Gateway**

1. **Internal calls between FXS ports**

Two analog phones connected to TA could make calls between them by dialing *99+FXS port number.

2. **Outbound and inbound calls**

Users should be able to make and receive external calls after configuring FXS Ports, VoIP Server, and Dial Pattern. Please refer to User Manual for details.

- **TA FXO Gateway**

1. **Route calls from a PSTN number to IP-PBX**

Users should be able to receive PSTN-to-VoIP call after configuring FXO Ports, VoIP trunk and Port -> IP. Please refer to User Manual for details.

2. **Route calls from VoIP trunk to a PSTN number**

Users should be able to make VoIP-to-PSTN call after configuring FXO Ports, VoIP trunk and IP ->Port. Please refer to User Manual for details.

4.5 Reset to Factory Defaults

To reset to factory defaults, you could follow the below instruction:

Press the "RESET" button located in the back panel with a paper clip or a pencil tip. You can see the RUN indicator stops flicker and turns solid. When the RUN indicator turns off, the button could be released and system begins to reset.

Note:

- During the process, please do not power off until the RUN indicator become normal which means the reset process is completed.
- After resetting, all the configurations made by the admin would be erased.

5. Conclusion

This Installation Guide only explains the installation and basic settings of TA Series Analog VoIP Gateways. For more functionality and advanced settings, please refer to the relative documents as below:

“TA Series Analog VoIP Gateways Datasheet”

“Yeastar_TA400&TA800_User_Manual_en”

“Yeastar_TA1600&TA2400&TA3200_User_Manual_en”

“Yeastar_TA410&TA810_User_Manual_en”

“Yeastar_TA1610_User_Manual_en”

[The End]